

Valk Welding Group

Tel +31 78 69 170 11
info@valkwelding.com
www.valkwelding.com



FRAME-H

NC
NEDERLANDSE
CNC

CE
2006/42/EG
2011/18/UE

CE
2006/42/EG
2011/18/UE

NC
NEDERLANDSE
CNC

CE
2006/42/EG
2011/18/UE

FRAME-H

System with 2 workstations

The "Frame-H" system developed by Valk Welding is a very successful concept. The system consists of two workstations where the robot is mounted in the middle between both stations. Both stations have a single-axis, freely programmable manipulator with counter bearing to present parts to the robot in the best possible way.

There are a number of important features that characterize this Valk Welding solution:

- Two workstations with the robot mounted fixed in the middle between both stations.
- Both stations have a single axis freely programmable positioner with counter bearing to position your parts in the best possible way to the robot.

The key features of this Valk Welding development are:

- The complete system is torsion free and easily "Plug & Play" moveable. Therefore all programs will remain perfect after transport of the system later.
- Also the controller and cooler are mounted on a platform connected to the frame so that the complete system is transportable.
- The entire frame has been machined so that all components are and will remain perfectly aligned.
- It is possible to replicate the system in order to create identical systems among which the programs are exchangeable.
- Compared to other concepts, the programmer stands towards the robot with the welding jig in between while programming. This makes programming easier and safer as when standing between robot and welding jig.
- There is no mechanical interaction between the two workstations. Loading heavy parts in one station and light parts in the other is perfectly possible.

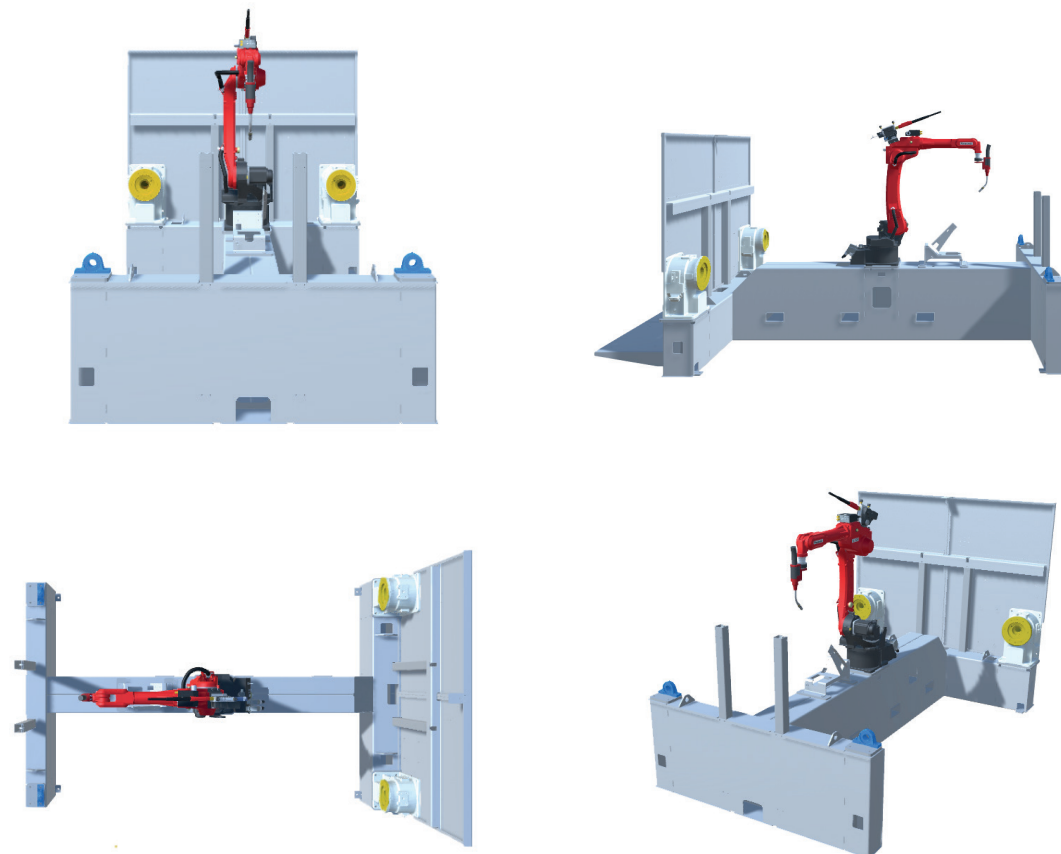

Watch the video

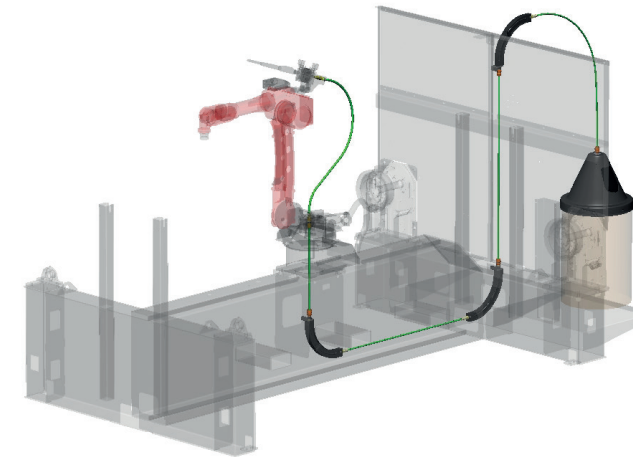

Watch the video

- In terms of logistics, a "Frame-H" is a better solution than a turntable concept:
 - Supply and removal of different parts separated from each other.
 - Pallets with parts can also be placed inside the workstation, reducing operator walking distance and floor print.
 - As soon as the robot is ready in a workstation, the operator immediately can enter the zone.
 - Changing jig or performing maintenance at one station does not interfere with production at the other station.
 - Shorter cycle times as the welding jig already can rotate while the robot moves from one workstation to another.
- The "Frame-H" system can be supplied in different dimensions according to your needs.
- It is also possible to equip the system with 2 robots (TWIN configuration).



The strong connection



Valk Welding NL
Staalindustrieweg 15
2952 AT Alblasterdam
Tel. +31 78 69 170 11

Valk Welding BE
Tel. +32 3 685 14 77

Valk Welding FR
Tél. +33 3 44 09 08 52

Valk Welding DK
Tel. +45 64 42 12 01

Valk Welding CZ
Tel. +420 556 73 0954

Valk Welding DE
Tel. +49 152 29 109 708

Valk Welding PL
Tel. +48 696 100 686

Valk Welding SE
Tel. +46 510 48 88 80

Valk Welding IE
Tel. +44 28 3886 8139

info@valkwelding.com
www.valkwelding.com